





# DATA IMAGE CORPORATION

## LCD Module Specification

ITEM NO.: CM080200NRNNA-01

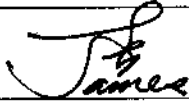
### Table of Contents

|   |    |
|---|----|
| 1. COVER & CONTENTS .....               | 1  |
| 2. RECORD OF REVISION .....             | 2  |
| 3. GENERAL SPECIFICATIONS .....         | 3  |
| 4. ABSOLUTE MAXIMUM RATINGS .....       | 4  |
| 5. ELECTRICAL CHARACTERISTICS .....     | 6  |
| 6. ELECTRO-OPTICAL CHARACTERISTIC ..... | 6  |
| 7. TIMING CHARACTERISTICS .....         | 8  |
| 8. PIN CONNECTIONS .....                | 10 |
| 9. POWER SUPPLY .....                   | 10 |
| 10. BLOCK DIAGRAM .....                 | 11 |
| 11. QUALITY ASSURANCE .....             | 18 |
| 12. LOT NUMBERING SYSTEM .....          | 22 |
| 13. LCM NUMBERING SYSTEM .....          | 22 |
| 14. PRECAUTIONS IN USE LCM .....        | 23 |
| 15. OUTLINE DRAWING .....               | 24 |
| 16. PACKAGE INFORMATION.....            | 25 |

|   |   |   |   |
|---|---|---|---|
| R&D Dept.   | Q.C. Dept.  | Eng. Dept.  | Prod. Dept.   |
|  |  |  |  |
| Version:  | Issued Date:  | Sheet Code:   | Total Pages:  |
|   | 2002/7/9  |   | 25  |

## 2. RECORD OF REVISION

| Rev | Date     | Item | Page | Comment   |
|-----|----------|------|------|---|
|     | JUL/9/02 | 13   | 22   | Change: P/N from CM0820NR-J2 to<br>CM080200NRNNA-01 |

### 3. GENERAL SPECIFICATION

- Display Format : 8characters (W) × 2lines (H)
- Character Size : 2.945 (W) × 5.545 (H) mm
- View Area : 35 (W) × 16 (H) mm
- General Dimensions : 58 (W) × 32 (H) × 10 (T) mm Max.
- Weight : 18 g max.
- LCD Type : STN Gray STN Yellow FSTN TN
- Polarizer mode : Reflective Transflective
- Transmissive Negative
- View Angle : 6 O'clock 12 O'clock Others \_\_\_\_\_
- Backlight : LED EL CCFL
- Backlight Color : Yellow green Amber Blue Green
- White Others
- Controller / Driver : KS0066
- Temperature Range : Normal Wide Temperature
- |           |             |           |             |
|-----------|-------------|-----------|-------------|
| Operating | 0 to 50°C   | Operating | -20 to 70°C |
| Storage   | -20 to 70°C | Storage   | -30 to 80°C |

## 4. ABSOLUTE MAXIMUM RATINGS

### 4.1 ELECTRICAL ABSOLUTE MAXIMUM RATINGS

$V_{SS}=0V$ ,  $T_a = 25^{\circ}C$

| Item                        | Symbol           | Min.            | Max.            | Unit |
|-----------------------------|------------------|-----------------|-----------------|------|
| Supply Voltage (Logic)      | VDD-VSS          | 0               | 7               | V    |
| Supply Voltage (LCD Driver) | VDD-VEE          | 1.5             | 13.5            | V    |
| Input Voltage               | V <sub>I</sub>   | V <sub>SS</sub> | V <sub>DD</sub> | V    |
| Operating Temperature       | T <sub>OP</sub>  | 0               | 50              | °C   |
| Storage Temperature         | T <sub>STG</sub> | -20             | 70              | °C   |

### 4.2 ENVIRONMENTAL ABSOLUTE MAXIMUM RATINGS

| Item         | Operating |                      | Storage |                      | Comment              |
|--------------|-----------|----------------------|---------|----------------------|----------------------|
|              | (Min.)    | Max.)                | (Min.)  | (Max.)               |                      |
| Ambient Temp | 0         | 50                   | -20     | 70                   | Note (1)             |
| Humidity     | Note (2)  |                      | Note(2) |                      | Without Condensation |
| Vibration    | --        | 4.9M/S <sup>2</sup>  | --      | 19.6M/S <sup>2</sup> | XYZ Direction        |
| Shock        | --        | 29.4M/S <sup>2</sup> | --      | 490M/S <sup>2</sup>  | XYZ Direction        |

Note(1)  $T_a = 0^{\circ}C$  : 50Hr Max.

Note(2)  $T_a \leq 40^{\circ}C$  : 90% RH Max.

$T_a \geq 40^{\circ}C$  : Absolute humidity must be lower than the humidity of 90% RH at 40°C.

### 4. 3 Electronic Static Discharge maximum rating

ESD test method : IEC1000-4-2

| Item                | Description  |                                |
|---------------------|--|--------------------------------|
| Testing environment | Ambient temperature :15°C to 35 °C<br>Humidity: 30% to 60 %<br>LCM ( E.U.T ) : Power up      |                                |
| Testing equipment   | Manufacture: NoiseKen, Model No. ESD-100L  |                                |
| Testing condition   | See drawing 1  |                                |
| Direct discharge    | 0 to ± 6 KV  | Discharge point, see drawing 2 |
| Indirect discharge  | 0 to ± 12KV  | Discharge point, see drawing 1 |
| Pass condition      | No malfunction of unit. Temporary malfunction of unit which can be recovered by system reset |                                |
| Fail condition      | Non. Recoverable malfunction of LCM or system  |                                |

FIG 1 ESD TESTING EQUIPMENT

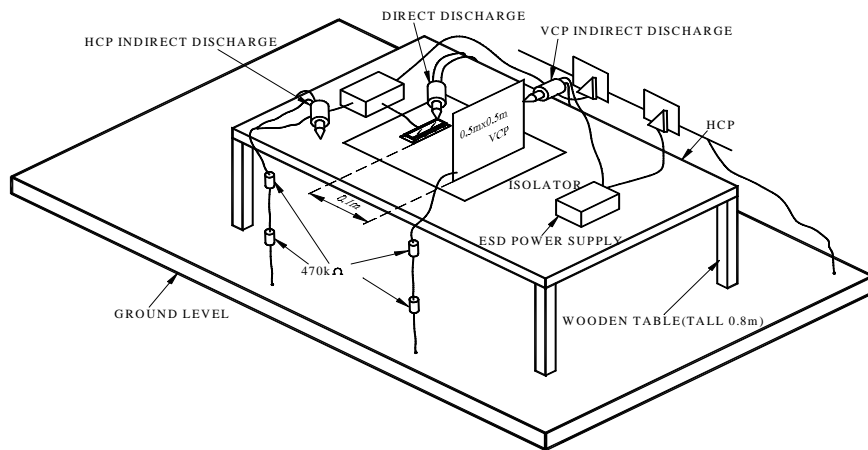

(1)

### DIRECT CONTACT DISCHARGE

CONTACT POINT : A.B.C.D

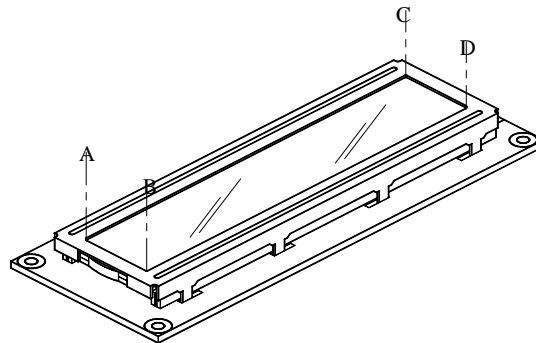

(2)

## 5. ELECTRICAL CHARACTERISTICS

| Item                   | Symbol          | Condition  | Min.    | Typ. | Max.    | Unit |
|------------------------|-----------------|------------|---------|------|---------|------|
| Supply Voltage (Logic) | VDD-VSS         |            | 2.7     | 5.0  | 5.5     | V    |
| Supply Voltage (LCD)   | VDD-VEE         | 0°C        | 4.3     | 4.5  | 4.7     | V    |
|                        |                 | 25°C       | 4.1     | 4.3  | 4.5     |      |
|                        |                 | 50°C       | 3.6     | 3.8  | 4.0     |      |
| Input Voltage          | V <sub>IH</sub> | --         | 0.7*VDD | --   | VDD     | V    |
|                        | V <sub>IL</sub> |            | VSS     | --   | 0.3*VDD |      |
| Logic Supply Current   | I <sub>DD</sub> | VDD-VSS=5V | --      | 1.0  | --      | mA   |

## 6. ELECTRO-OPTICAL CHARACTERISTICS

| ITEM            | Symbol  | Condition      | Min. | Typ. | Max. | Unit | Ref.     |
|-----------------|---|----------------|------|------|------|------|----------|
| Rise Time       | Tr  | 0°C            | --   | 300  | 500  | ms   | Note (1) |
|                 |   | 25°C           |      | 100  | 200  |      |          |
| Fall Time       | Tf  | 0°C            | --   | 500  | 850  | ms   |          |
|                 |   | 25°C           |      | 150  | 300  |      |          |
| Contrast        | CR  | 25°C           | 2    | 4    | --   |      | Note (3) |
| View Angle      | θ <sub>1</sub> ~θ <sub>2</sub><br>∅ <sub>1</sub> , ∅ <sub>2</sub> | 25°C &<br>CR≥2 | --   | 80   | --   |      | Note (2) |
|                 |   |                | --   | 30   | --   |      |          |
| Frame Frequency | Ff  | 25°C           | --   | 64   | --   | Hz   |          |

Note (1) & (2) : See next page

Note (3) : Contrast ratio is defined under the following condition:

$$CR = \frac{\text{Brightness of non-selected condition}}{\text{Brightness of selected condition}}$$

- ( a ). Temperature ----- 25°C
- ( b ). Frame frequency ---- 64Hz
- ( c ). Viewing angle ----- θ= 0°, ∅ = 0°
- ( d ). Operating voltage --- 4.3V

Note (1) Response time is measured as the shortest period of time possible between the change in state of an LCD segment as demonstrated below:

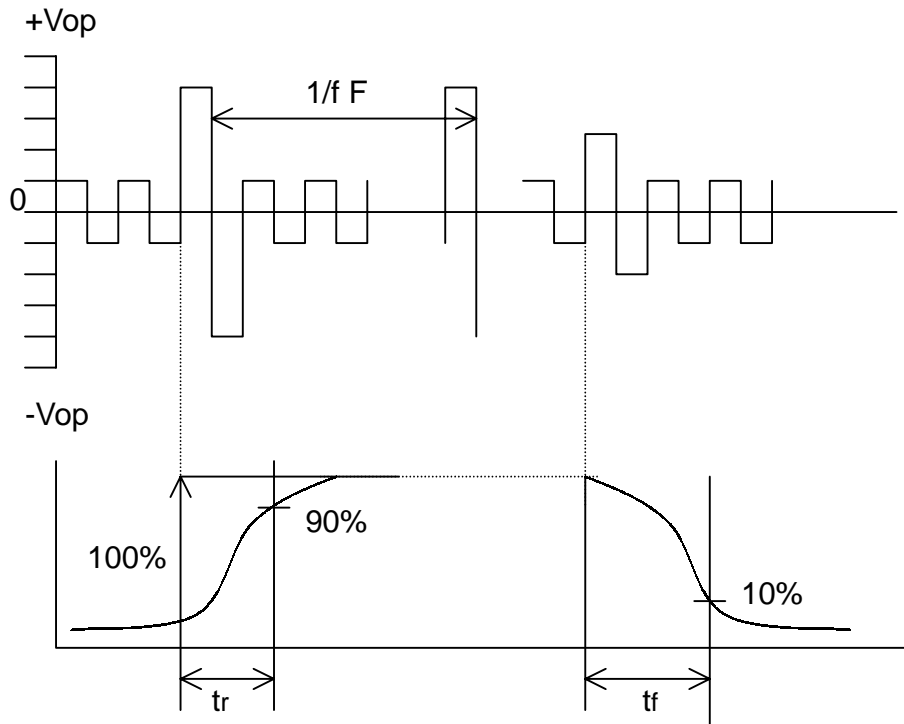

Condition:

- ( a ) . Temperature ----- $25^{\circ}C$
- ( b ) . Frame frequency ----- 64Hz
- ( c ) . View Angle -----  $\theta = 0^{\circ}$ ,  $\phi = 0^{\circ}$
- ( d ) . Operating voltage ----- 4.3V

Note (2) Definition of View Angle

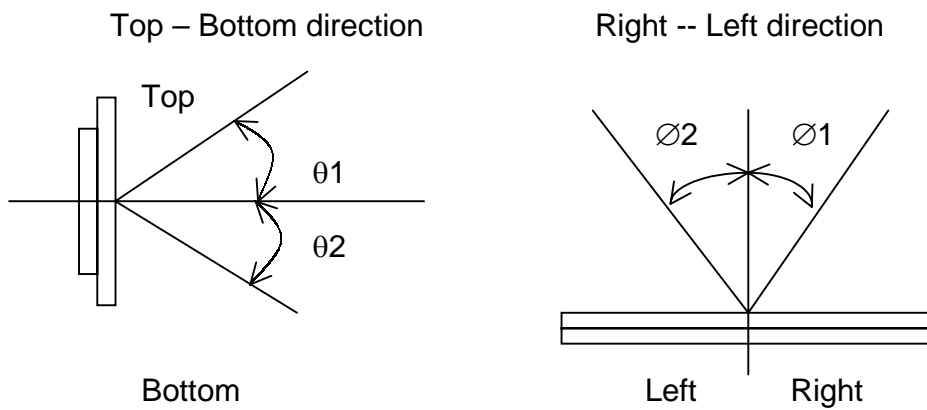

## 7. TIMING CHARACTERISTICS

### 7.1 WRITE TIMING

AC characteristics (VDD=4.5v~5.5v, Ta=-30~85°C)

| Item                       | Symbol | Condition | Min. | Max. | Unit |
|----------------------------|--------|-----------|------|------|------|
| E cycle time               | tc     | VDD = 5V  | 500  | --   | ns   |
| E pulse width (high level) | tw     |           | 230  | --   |      |
| E rise/fall time           | tR, tF |           | --   | 20   |      |
| R/W and RS Setup time      | tsu1   |           | 40   | --   |      |
| R/W and RS Hold time       | tH1    |           | 10   | --   |      |
| Data setup time            | tsu2   |           | 80   | --   |      |
| Data hold time             | tH2    |           | 10   | --   |      |

AC characteristics (VDD=2.7v~4.5v, Ta=-30~85°C)

| Item                       | Symbol | Condition | Min. | Max. | Unit |
|----------------------------|--------|-----------|------|------|------|
| E cycle time               | tc     | VDD = 3V  | 1000 | --   | ns   |
| E pulse width (high level) | tw     |           | 450  | --   |      |
| E rise/fall time           | tR, tF |           | --   | 25   |      |
| R/W and RS Setup time      | tsu1   |           | 60   | --   |      |
| R/W and RS Hold time       | tH1    |           | 20   | --   |      |
| Data setup time            | tsu2   |           | 195  | --   |      |
| Data hold time             | tH2    |           | 10   | --   |      |

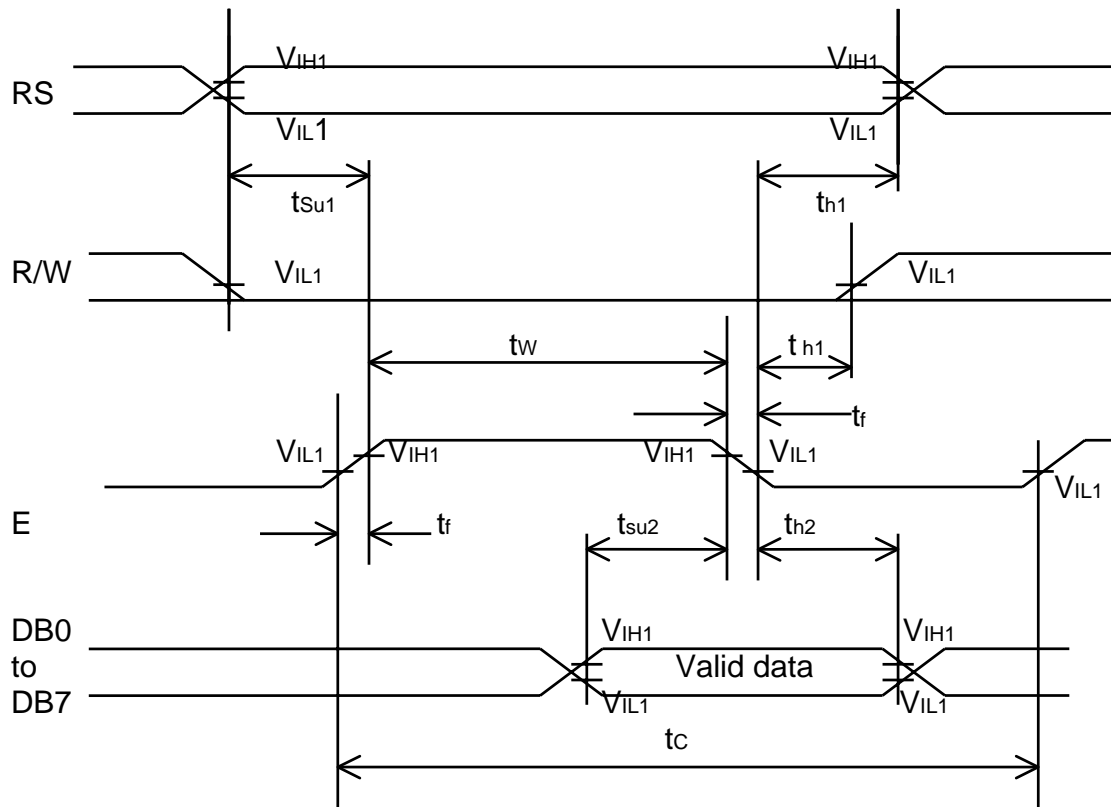

## 7.2 READ TIMING

AC characteristics (VDD=4.5v~5.5v, Ta=-30~85°C)

| Item                       | Symbol | Condition | Min. | Max. | Unit |
|----------------------------|--------|-----------|------|------|------|
| E cycle time               | tc     | VDD = 5V  | 500  | --   | ns   |
| E pulse width (high level) | tw     |           | 230  | --   |      |
| E rise/fall time           | tR, tF |           | --   | 20   |      |
| R/W and RS shetup time     | tsu    |           | 40   | --   |      |
| R/W and RS hold time       | tH     |           | 10   | --   |      |
| Data output delay time     | tD     |           | --   | 120  |      |
| Data hold time             | tDH    |           | 5    | --   |      |

AC characteristics (VDD=2.7v~4.5v, Ta=-30~85°C)

| Item                       | Symbol | Condition | Min. | Max. | Unit |
|----------------------------|--------|-----------|------|------|------|
| E cycle time               | tc     | VDD = 3V  | 1000 | --   | ns   |
| E pulse width (high level) | tw     |           | 450  | --   |      |
| E rise/fall time           | tR, tF |           | --   | 25   |      |
| R/W and RS setup time      | tsu    |           | 60   | --   |      |
| R/W and RS hold time       | tH     |           | 20   | --   |      |
| Data output delay time     | tD     |           | --   | --   |      |
| Data hold time             | tDH    |           | 5    | --   |      |

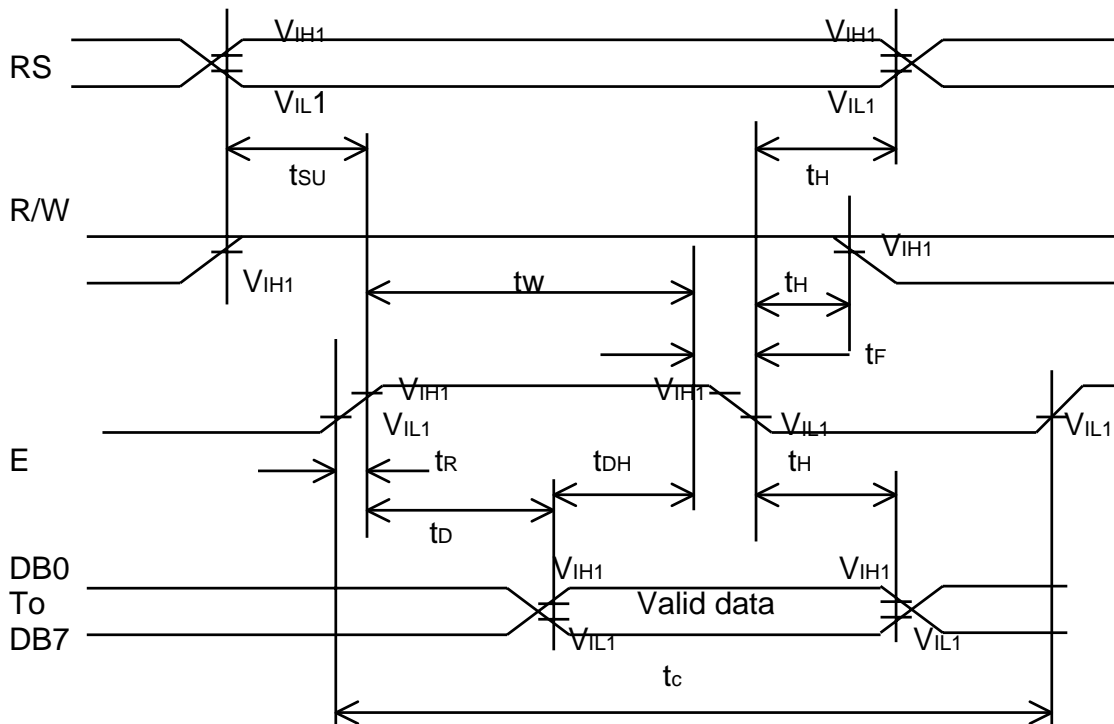

## 8. PIN CONNECTIONS

| No. | Symbol | Function                             |
|-----|--------|--------------------------------------|
| 1   | VSS    | Ground, 0V                           |
| 2   | VDD    | Logic power supply, +5V              |
| 3   | VEE    | Voltage for LCD drive                |
| 4   | RS     | Data / Instruction register select   |
| 5   | R/W    | Read / Write                         |
| 6   | E      | Enable signal, start data read/write |
| 7   | DB0    | Data Bus Line                        |
| 8   | DB1    |                                      |
| 9   | DB2    |                                      |
| 10  | DB3    |                                      |
| 11  | DB4    |                                      |
| 12  | DB5    |                                      |
| 13  | DB6    |                                      |
| 14  | DB7    |                                      |
| 15  | LED A  | LED Anode, power supply +            |
| 16  | LED K  | LED Cathode, ground 0V               |

## 9. POWER SUPPLY

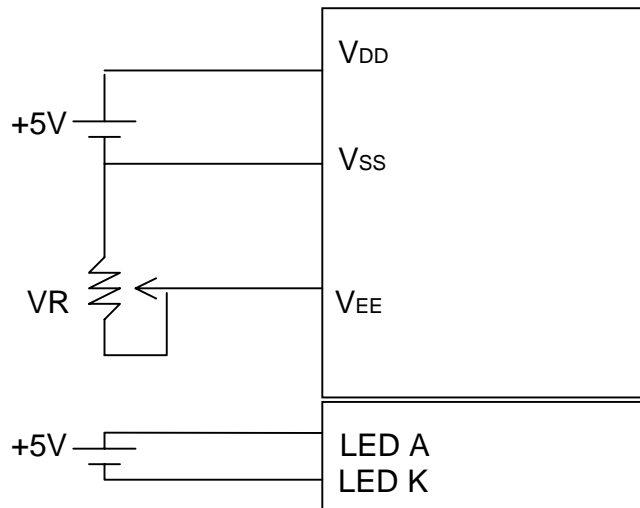

VR = 10K

## 10. BLOCK DIAGRAM

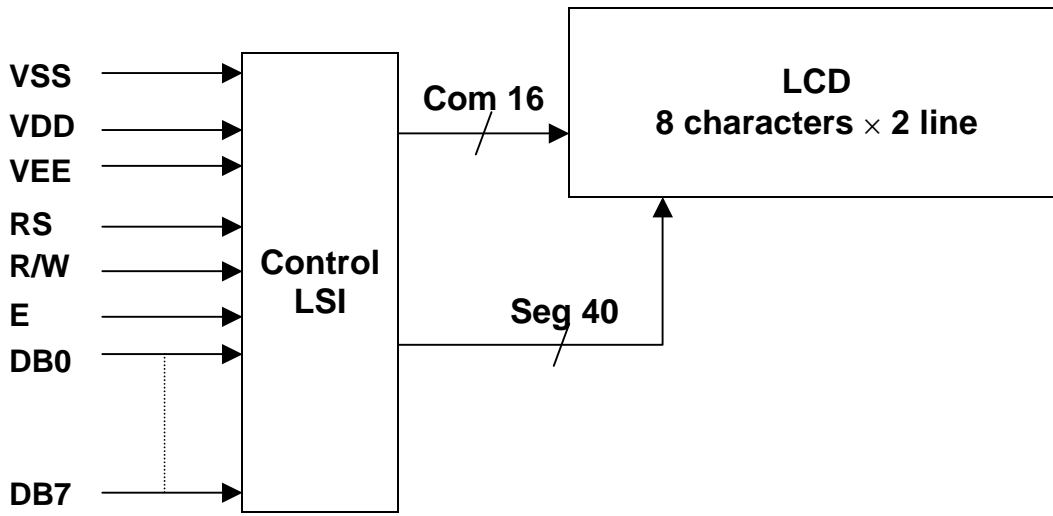

## 10.1 INSTRUCTIONS

| Instruction                | Instruction Code |     |     |     |     |     |     |     |     |     | DESCRIPTION   | Executed Time( fosc =270KHz) |
|----------------------------|------------------|-----|-----|-----|-----|-----|-----|-----|-----|-----|---|------------------------------|
|                            | RS               | R/W | DB7 | DB6 | DB5 | DB4 | DB3 | DB2 | DB1 | DB0 |   |                              |
| Clear Display              | 0                | 0   | 0   | 0   | 0   | 0   | 0   | 0   | 0   | 1   | Write "20H" to DDRAM and set DDRAM address to "00H" from AC   | 1.53mS                       |
| Cursor At Home             | 0                | 0   | 0   | 0   | 0   | 0   | 0   | 0   | 1   | -   | Set DDRAM address to "00H" from AC and return cursor to its original Position if shifted.<br>The contents of DDRAM are not changed. | 1.53mS                       |
| Entry Mode Set             | 0                | 0   | 0   | 0   | 0   | 0   | 0   | 1   | I/D | SH  | Assign cursor moving direction and enable the shift of entire display.  | 39μS                         |
| Display On/Off Control     | 0                | 0   | 0   | 0   | 0   | 0   | 1   | D   | C   | B   | Set display (D), cursor(C), and Blinking of cursor(B) ON/OFF control bit.   | 39μS                         |
| Cursor or Display Shift    | 0                | 0   | 0   | 0   | 0   | 1   | S/C | R/L | -   | -   | Set cursor moving and display shifts cursor bit, and the direction, without changing of DDRAM data.                                 | 39μS                         |
| Function Set               | 0                | 0   | 0   | 0   | 1   | DL  | N   | F   | -   | -   | Sets interface data length (DL:8-BIT/4-BIT), number of display lines(N:2-line/1-line) and, display font type (F:5x11dots/5x8 dots). | 39μS                         |
| Set CGRAM Address          | 0                | 0   | 0   | 1   | AC5 | AC4 | AC3 | AC2 | AC1 | AC0 | Set CGRAM address in address counter.   | 39μS                         |
| Set DDRAM Address          | 0                | 0   | 1   | AC6 | AC5 | AC4 | AC3 | AC2 | AC1 | AC0 | Set DDRAM address in address counter.   | 39μS                         |
| Read Busy Flag and Address | 0                | 1   | BF  | AC6 | AC5 | AC4 | AC3 | AC2 | AC1 | AC0 | Whether during internal operation or not can be known by reading BF.<br>The contents of address counter can also be read.           | 0μS                          |
| Write Data to RAM          | 1                | 0   | D7  | D6  | D5  | D4  | D3  | D2  | D1  | D0  | Write data into internal RAM (DDRAM / CGRAM)  | 43μS                         |
| Read Data from RAM         | 1                | 1   | D7  | D6  | D5  | D4  | D3  | D2  | D1  | D0  | Reads data from internal RAM (DDRAM / CGRAM).   | 43μS                         |

\*"-":don't care

**NOTE : When an MPU program with checking the Busy Flag(DB7) is made, it must be necessary 1/2Fosc is necessary for executing the next instruction by the falling edge of the 'E' signal after the Busy Flag(DB7) goes to "LOW" .**

## 10.2 8-Bit Operation, 8-Digit×2-Line Display Example

| Step | Instruction   |     |     |     |     |     |     |     |     |     | Display | Operation   |
|------|---|-----|-----|-----|-----|-----|-----|-----|-----|-----|---------|---|
| No   | RS  | R/W | DB7 | DB6 | DB5 | DB4 | DB3 | DB2 | DB1 | DB0 | Display | Operation   |
| 1    | Power supply on (the HD44780U is initialized by the Internal reset circuit) |     |     |     |     |     |     |     |     |     |         | Initialized. No display.  |
| 2    | 0   | 0   | 0   | 0   | 1   | 1   | 1   | 0   | *   | *   |         | Sets to 8-bit operation and selects 2-line display and 5×8 dot character font.  |
| 3    | Display on/off control  |     |     |     |     |     |     |     |     |     |         | Turns on display and cursor. All display is in space mode because of initialization.  |
| 4    | Entry mode set  |     |     |     |     |     |     |     |     |     |         | Sets mode to increment the address by one and to shift the cursor to the right at the time of write to the DD/CGRAM. Display is not shifted.        |
| 5    | Write data to CGRAM/DDRAM   |     |     |     |     |     |     |     |     |     |         | Writes H. DDRAM has already been selected by initialization when the power was turned on. The cursor is incremented by one and shifted to the right |
| 6    | ⋮   |     |     |     |     |     |     |     |     |     | ⋮       |   |
| 7    | Write data to CGRAM/DDRAM   |     |     |     |     |     |     |     |     |     |         | Writes I.   |
| 8    | Set DDRAM address   |     |     |     |     |     |     |     |     |     |         | Sets DDRAM address so that the cursor is positioned at the Head of the second line.   |
| 9    | Write data to CGRAM/DDRAM   |     |     |     |     |     |     |     |     |     |         | Writes M.   |
| 10   | ⋮   |     |     |     |     |     |     |     |     |     | ⋮       |   |
| 11   | Write data to CGRAM/DDRAM   |     |     |     |     |     |     |     |     |     |         | Writes O.   |
| 12   | Entry mode set  |     |     |     |     |     |     |     |     |     |         | Sets mode to shift display at the time of write.  |
| 13   | Write data to CGRAM/DDRAM   |     |     |     |     |     |     |     |     |     |         | Writes M. Display is shifted to the left. The first and second lines both shift at the same time.   |
| 14   | ⋮   |     |     |     |     |     |     |     |     |     | ⋮       |   |
| 15   | Return home   |     |     |     |     |     |     |     |     |     |         | Returns both display and cursor to the original position (address 0).   |

### 10.3 Interfacing to the MPU

The HD44780U can send data in either two 4-bit operations, thus allowing interfacing with 4- or 8-bit MPUs.

- For 4-bit interface data, only four bus lines (DB4 to DB7) are used for transfer. Bus lines DB0 to DB3 are disabled. The data transfer between the HD44780U and the MPU is completed after the 4-bit data has been transferred twice. As for the order of data transfer, the four high order bits (for 8-bit operation, DB4 to DB7) are transferred before the four low order bits (for 8-bit operation, DB0 to DB3). The busy flag must be checked (one instruction) after the 4-bit data has been transferred twice. Two more 4-bit operations then transfer the busy flag and address counter data.

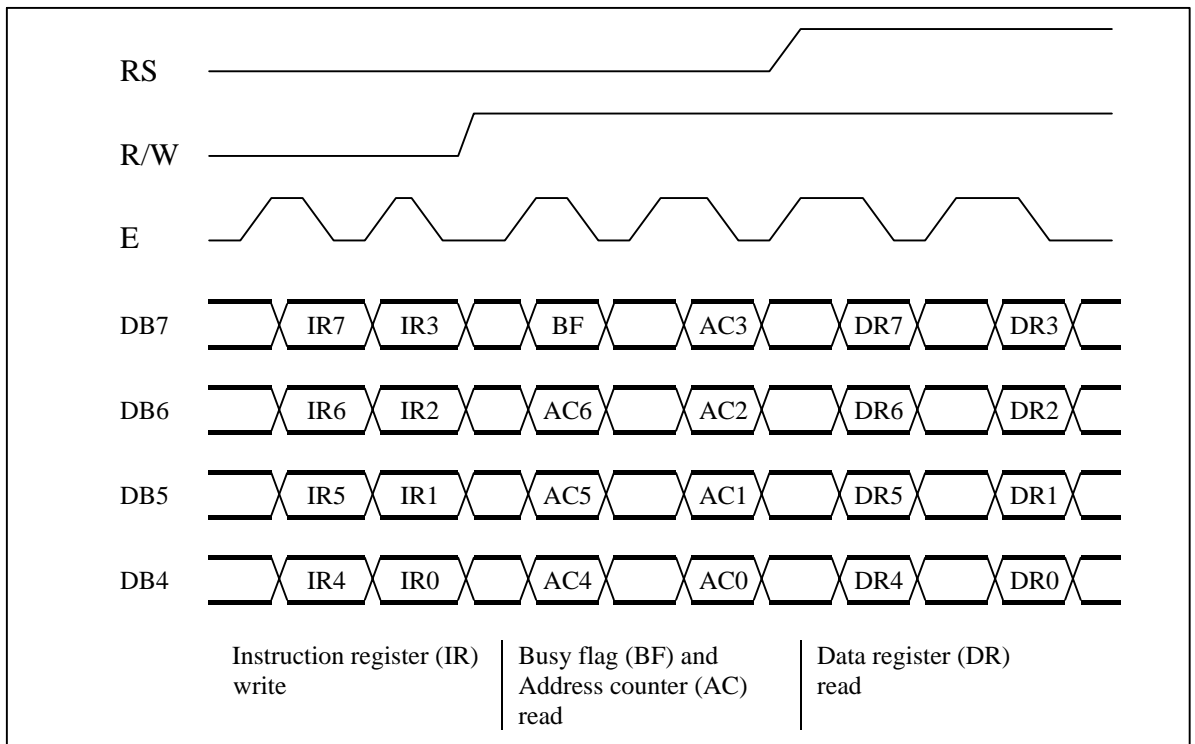

4-Bit Transfer Example

# 10.4 1-Line Display

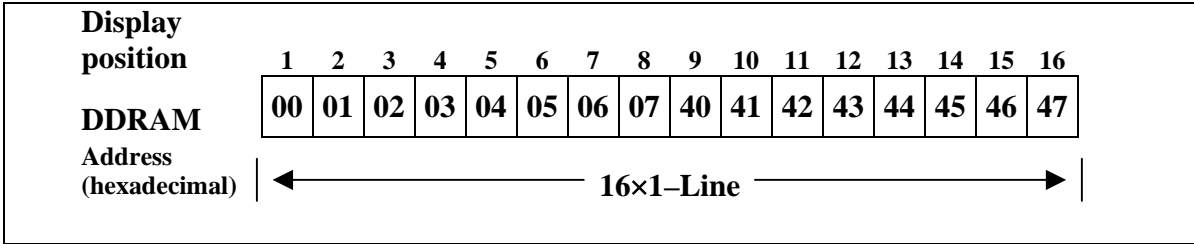

## 2-Line Display

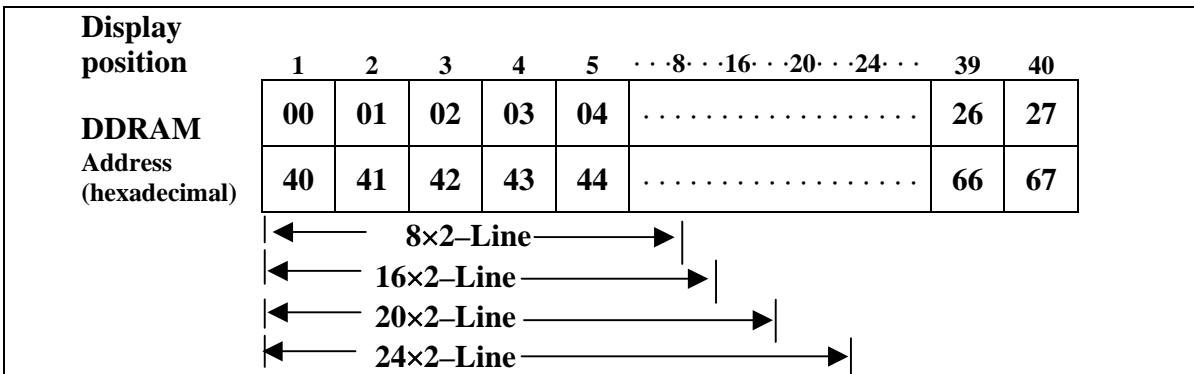

## 4-Line Display

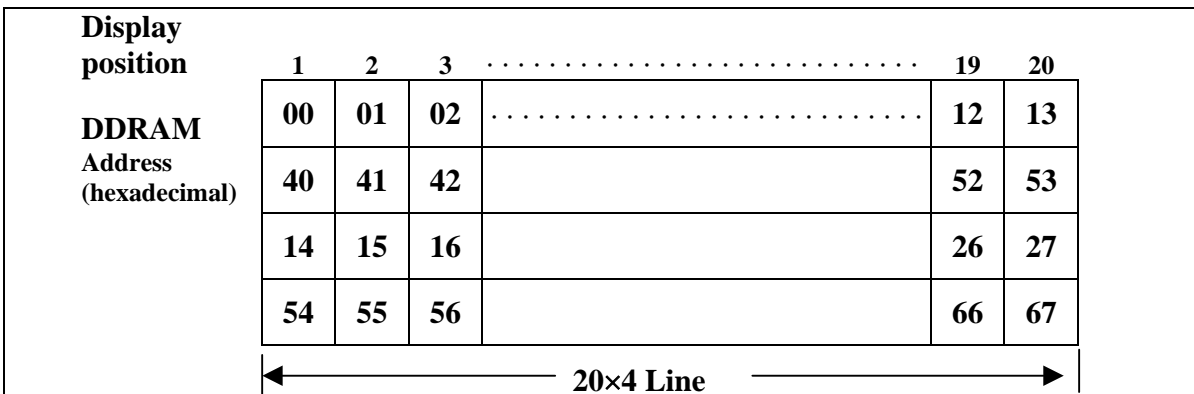
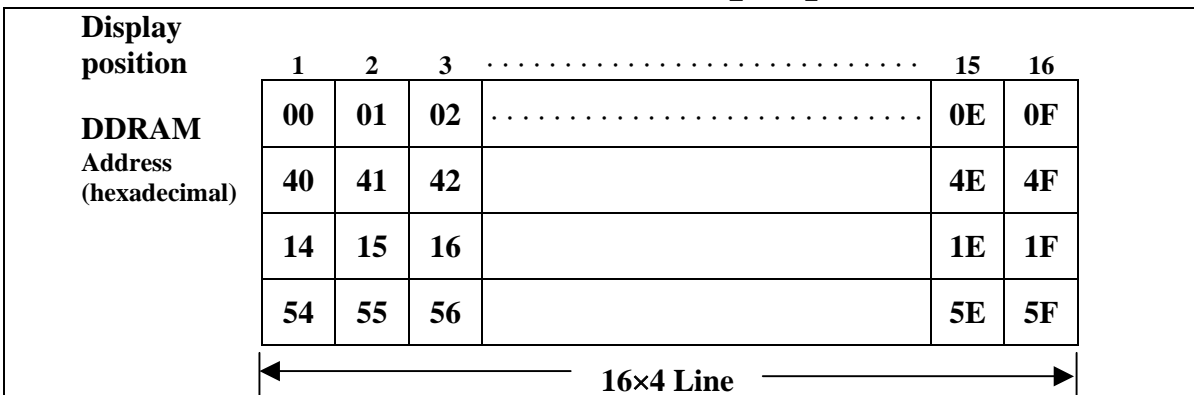

## 10.5 CGRAM

Relationship between CGRAM Addresses, Character Codes (DDRAM) and Patterns (CGRAM Data)

For 5x8 dot character patterns

| Character Codes (DDRAM data) |  | CGRAM Address |       | Character Patterns (CGRAM data) |                       |
|------------------------------|--|---------------|-------|---------------------------------|-----------------------|
| 7 6 5 4 3 2 1 0              |  | 5 4 3 2 1 0   |       | 7 6 5 4 3 2 1 0                 |                       |
| High Low                     |  | High Low      |       | High Low                        |                       |
| 0 0 0 0 * 0 0 0              |  | 0 0 0         | 0 0 0 | ** * 1 1 1 1 0                  | Character Pattern (1) |
|                              |  |               | 0 0 1 | 1 0 0 0 1                       |                       |
|                              |  |               | 0 1 0 | 1 0 0 0 1                       |                       |
|                              |  |               | 0 1 1 | 1 1 1 1 0                       |                       |
|                              |  |               | 1 0 0 | 1 0 1 0 0                       |                       |
|                              |  |               | 1 0 1 | 1 0 0 1 0                       | Cursor position       |
|                              |  |               | 1 1 0 | 1 0 0 0 1                       |                       |
|                              |  |               | 1 1 1 | ** * 0 0 0 0 0                  |                       |
| 0 0 0 0 * 0 0 1              |  | 0 0 1         | 0 0 0 | ** * 1 0 0 0 1                  | Character Pattern (2) |
|                              |  |               | 0 0 1 | 0 1 0 1 0                       |                       |
|                              |  |               | 0 1 0 | 1 1 1 1 1                       |                       |
|                              |  |               | 0 1 1 | 0 0 1 0 0                       |                       |
|                              |  |               | 1 0 0 | 1 1 1 1 1                       |                       |
|                              |  |               | 1 0 1 | 0 0 1 0 0                       | Cursor position       |
|                              |  |               | 1 1 0 | 0 0 1 0 0                       |                       |
|                              |  |               | 1 1 1 | ** * 0 0 0 0 0                  |                       |
|                              |  |               | 0 0 0 | ** *                            |                       |
|                              |  |               | 0 0 1 | ** *                            |                       |
| 0 0 0 0 * 1 1 1              |  | 1 1 1         | 1 0 0 | ** *                            |                       |
|                              |  |               | 1 0 1 |                                 |                       |
|                              |  |               | 1 1 0 |                                 |                       |
|                              |  |               | 1 1 1 |                                 |                       |

- Notes :
- Character code bits 0 to 2 correspond to CGRAM address bits 3 to 5 (3 bits: 8 types).
  - CGRAM address bits 0 to 2 designate the character pattern line position. The 8th line is the cursor position and its display is formed by a logical OR. Maintain the 8th line data, corresponding to the cursor display position, at 0 as the cursor display. If the 8th line data is 1, 1 bits will light up the 8th line regardless of the cursor presence.
  - Character pattern row positions correspond to CGRAM data bits 0 to 4 (bit 4 being at the left).
  - As shown Table 5, CGRAM character patterns are selected when character code bits 4 to 7 are all 0. However, since character code bit 3 has no effect, the R display example above can be selected by either character code 00H or 08H.
  - 1 for CGRAM data corresponds to display selection and 0 to non-selection.
- \* Indicates no effect.

### 10.6 Correspondence between Character Codes and Character Patterns (ROM Code:A00)

| Upper<br>RAM<br>Lower | 0000             | 0001 | 0010 | 0011 | 0100 | 0101 | 0110 | 0111 | 1000 | 1001 | 1010 | 1011 | 1100 | 1101 | 1110 | 1111 |
|-----------------------|------------------|------|------|------|------|------|------|------|------|------|------|------|------|------|------|------|
| xxxx0000              | CG<br>RAM<br>(1) |      |      | 0    | a    | P    | `    | P    |      |      |      | -    | 夕    | ミ    | α    | ρ    |
| xxxx0001              | (2)              |      | !    | 1    | A    | Q    | a    | q    |      |      | 。    | ア    | チ    | △    | ä    | q    |
| xxxx0010              | (3)              |      | "    | 2    | B    | R    | b    | r    |      |      | 「    | イ    | ツ    | ×    | β    | θ    |
| xxxx0011              | (4)              |      | #    | 3    | C    | S    | c    | s    |      |      | 」    | ウ    | テ    | ε    | ε    | ∞    |
| xxxx0100              | (5)              |      | \$   | 4    | D    | T    | d    | t    |      |      | 、    | エ    | ト    | †    | μ    | Ω    |
| xxxx0101              | (6)              |      | %    | 5    | E    | U    | e    | u    |      |      | ・    | オ    | ナ    | 工    | ε    | Ü    |
| xxxx0110              | (7)              |      | &    | 6    | F    | V    | f    | v    |      |      | ヲ    | カ    | ニ    | ヨ    | ρ    | Σ    |
| xxxx0111              | (8)              |      | '    | 7    | G    | W    | g    | w    |      |      | フ    | キ    | ヌ    | ラ    | g    | π    |
| xxxx1000              | (1)              |      | (    | 8    | H    | X    | h    | x    |      |      | ィ    | ク    | ネ    | リ    | フ    | ×    |
| xxxx1001              | (2)              |      | )    | 9    | I    | Y    | i    | y    |      |      | ウ    | ケ    | ル    | ル    | ”    | γ    |
| xxxx1010              | (3)              |      | *    | :    | J    | Z    | j    | z    |      |      | エ    | コ    | ン    | レ    | j    | ≠    |
| xxxx1011              | (4)              |      | +    | ;    | K    | C    | k    | c    |      |      | オ    | サ    | ヒ    | ロ    | *    | π    |
| xxxx1100              | (5)              |      | ,    | <    | L    | ¥    | l    | l    |      |      | カ    | シ    | フ    | ワ    | φ    | π    |
| xxxx1101              | (6)              |      | -    | =    | M    | J    | m    | j    |      |      | ユ    | ス    | ン    | ン    | も    | ÷    |
| xxxx1110              | (7)              |      | .    | >    | N    | ^    | n    | →    |      |      | ヨ    | セ    | ホ    | ”    | π    |      |
| xxxx1111              | (8)              |      | /    | ?    | O    | _    | o    | ←    |      |      | ッ    | ソ    | マ    | °    | ö    | ■    |

Note: The user can specify any pattern for character-generator RAM.

## 11. QUALITY ASSURANCE

### 11.1 Test Condition

#### 11.1.1 Temperature and Humidity(Ambient Temperature)

Temperature :  $20 \pm 5^{\circ}\text{C}$

Humidity :  $65 \pm 5\%$

#### 11.1.2 Operation

Unless specified otherwise, test will be conducted under function state.

#### 11.1.3 Container

Unless specified otherwise, vibration test will be conducted to the product itself without putting it in a container.

#### 11.1.4 Test Frequency

In case of related to deterioration such as shock test. It will be conducted only once.

#### 11.1.5 Test Method

| No. | Parameter                                | Conditions  | Regulations |
|-----|--|---|-------------|
| 1   | High Temperature Operating               | $50 \pm 2^{\circ}\text{C}$  | Note 3      |
| 2   | Low Temperature Operating                | $0 \pm 2^{\circ}\text{C}$   | Note 3      |
| 3   | High Temperature Storage                 | $70 \pm 2^{\circ}\text{C}$  | Note 3      |
| 4   | Low Temperature Storage                  | $-20 \pm 2^{\circ}\text{C}$   | Note 3      |
| 5   | Vibration Test<br>(Non-operation state)  | Total fixed amplitude : 1.5mm<br>Vibration Frequency : 10 ~ 55Hz<br>One cycle 60 seconds to 3 directions<br>of X.Y.Z. for each 15 minutes | Note 3      |
| 6   | Damp Proof Test<br>(Non-operation state) | $40^{\circ}\text{C} \pm 2^{\circ}\text{C}$ , 90~95%RH, 96h  | Note 1,2    |
| 7   | Shock Test<br>(Non-operation state)      | To be measured after dropping from<br>60cm high once concrete surface in<br>packing state   | Note 3      |

Note 1: Returned under normal temperature and humidity for 4 hrs.

Note 2: No dew condensation to be observed.

Note 3: No change on display and in operation under the test condition

## 11.2 Inspection condition

### 11.2.1 Inspection conditions

The LCD shall be inspected under 40W white fluorescent light.

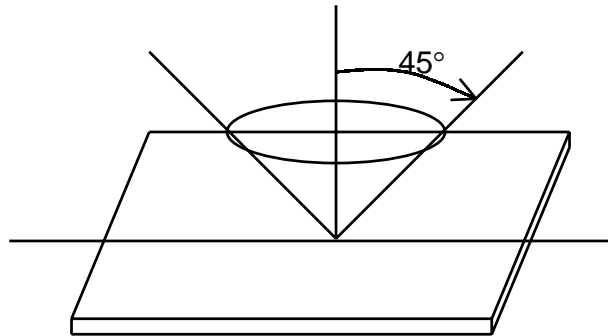

### 11.2.2 Definition of applicable Zones

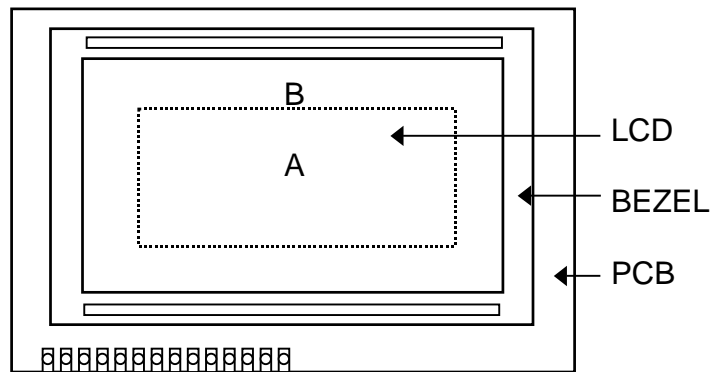

A : Display Area  
B : Non-Display Area

### 11.2.3 Inspection Parameters

| No.               | Parameter                                  | Criteria   |                   |                   |                   |                  |                  |           |        |          |   |   |       |          |                 |   |       |                |         |          |         |   |         |          |   |   |   |         |   |   |
|-------------------|--|--|-------------------|-------------------|-------------------|------------------|------------------|-----------|--------|----------|---|---|-------|----------|-----------------|---|-------|----------------|---------|----------|---------|---|---------|----------|---|---|---|---------|---|---|
| 1                 | Black or White spots                       | <table border="1"> <thead> <tr> <th rowspan="2">Zone<br/>Dimension</th> <th colspan="2">Acceptable number</th> <th rowspan="2">Class Of Defects</th> <th rowspan="2">AQL Level</th> </tr> <tr> <th>A</th> <th>B</th> </tr> </thead> <tbody> <tr> <td>D &lt; 0.15</td> <td>*</td> <td>*</td> <td rowspan="4">Minor</td> <td rowspan="4">2.5</td> </tr> <tr> <td>0.15 ≤ D &lt; 0.2</td> <td>4</td> <td>4</td> </tr> <tr> <td>0.2 ≤ D ≤ 0.25</td> <td>2</td> <td>2</td> </tr> <tr> <td>D ≤ 0.3</td> <td>0</td> <td>1</td> </tr> </tbody> </table> <p>D = (Long + Short) / 2      * : Disregard</p>  | Zone<br>Dimension | Acceptable number |                   | Class Of Defects | AQL Level        | A         | B      | D < 0.15 | * | * | Minor | 2.5      | 0.15 ≤ D < 0.2  | 4 | 4     | 0.2 ≤ D ≤ 0.25 | 2       | 2        | D ≤ 0.3 | 0 | 1       |          |   |   |   |         |   |   |
| Zone<br>Dimension | Acceptable number                          |  |                   | Class Of Defects  | AQL Level         |                  |                  |           |        |          |   |   |       |          |                 |   |       |                |         |          |         |   |         |          |   |   |   |         |   |   |
|                   | A  | B  |                   |                   |                   |                  |                  |           |        |          |   |   |       |          |                 |   |       |                |         |          |         |   |         |          |   |   |   |         |   |   |
| D < 0.15          | *  | *  | Minor             | 2.5               |                   |                  |                  |           |        |          |   |   |       |          |                 |   |       |                |         |          |         |   |         |          |   |   |   |         |   |   |
| 0.15 ≤ D < 0.2    | 4  | 4  |                   |                   |                   |                  |                  |           |        |          |   |   |       |          |                 |   |       |                |         |          |         |   |         |          |   |   |   |         |   |   |
| 0.2 ≤ D ≤ 0.25    | 2  | 2  |                   |                   |                   |                  |                  |           |        |          |   |   |       |          |                 |   |       |                |         |          |         |   |         |          |   |   |   |         |   |   |
| D ≤ 0.3           | 0  | 1  |                   |                   |                   |                  |                  |           |        |          |   |   |       |          |                 |   |       |                |         |          |         |   |         |          |   |   |   |         |   |   |
| 2                 | Scratch, Substances                        | <table border="1"> <thead> <tr> <th colspan="2">Zone</th> <th colspan="2">Acceptable number</th> <th rowspan="2">Class Of Defects</th> <th rowspan="2">AQL Level</th> </tr> <tr> <th>X (mm)</th> <th>Y(mm)</th> <th>A</th> <th>B</th> </tr> </thead> <tbody> <tr> <td>*</td> <td>0.04 ≥ W</td> <td>*</td> <td>*</td> <td rowspan="4">Minor</td> <td rowspan="4">2.5</td> </tr> <tr> <td>3.0 ≥ L</td> <td>0.06 ≥ W</td> <td>4</td> <td>4</td> </tr> <tr> <td>2.0 ≥ L</td> <td>0.08 ≥ W</td> <td>2</td> <td>3</td> </tr> <tr> <td>—</td> <td>0.1 &lt; W</td> <td>0</td> <td>1</td> </tr> </tbody> </table> <p>X : Length    Y : Width      * : Disregard</p> <p>Total defects should not exceed 4/module</p> | Zone              |                   | Acceptable number |                  | Class Of Defects | AQL Level | X (mm) | Y(mm)    | A | B | *     | 0.04 ≥ W | *               | * | Minor | 2.5            | 3.0 ≥ L | 0.06 ≥ W | 4       | 4 | 2.0 ≥ L | 0.08 ≥ W | 2 | 3 | — | 0.1 < W | 0 | 1 |
| Zone              |  | Acceptable number  |                   | Class Of Defects  | AQL Level         |                  |                  |           |        |          |   |   |       |          |                 |   |       |                |         |          |         |   |         |          |   |   |   |         |   |   |
| X (mm)            | Y(mm)                                      | A  | B                 |                   |                   |                  |                  |           |        |          |   |   |       |          |                 |   |       |                |         |          |         |   |         |          |   |   |   |         |   |   |
| *                 | 0.04 ≥ W                                   | *  | *                 | Minor             | 2.5               |                  |                  |           |        |          |   |   |       |          |                 |   |       |                |         |          |         |   |         |          |   |   |   |         |   |   |
| 3.0 ≥ L           | 0.06 ≥ W                                   | 4  | 4                 |                   |                   |                  |                  |           |        |          |   |   |       |          |                 |   |       |                |         |          |         |   |         |          |   |   |   |         |   |   |
| 2.0 ≥ L           | 0.08 ≥ W                                   | 2  | 3                 |                   |                   |                  |                  |           |        |          |   |   |       |          |                 |   |       |                |         |          |         |   |         |          |   |   |   |         |   |   |
| —                 | 0.1 < W                                    | 0  | 1                 |                   |                   |                  |                  |           |        |          |   |   |       |          |                 |   |       |                |         |          |         |   |         |          |   |   |   |         |   |   |
| 3                 | Air Bubbles<br>(between glass & polarizer) | <table border="1"> <thead> <tr> <th rowspan="2">Zone<br/>Dimension</th> <th colspan="2">Acceptable number</th> <th rowspan="2">Class of Defects</th> <th rowspan="2">AQL Level</th> </tr> <tr> <th>A</th> <th>B</th> </tr> </thead> <tbody> <tr> <td>D ≤ 0.15</td> <td>*</td> <td>*</td> <td rowspan="3">Minor</td> <td rowspan="3">2.5</td> </tr> <tr> <td>0.15 &lt; D ≤ 0.25</td> <td>2</td> <td>*</td> </tr> <tr> <td>0.25 &lt; D</td> <td>0</td> <td>1</td> </tr> </tbody> </table> <p>* : Disregard</p> <p>Total defects shall not excess 3/module.</p>   | Zone<br>Dimension | Acceptable number |                   | Class of Defects | AQL Level        | A         | B      | D ≤ 0.15 | * | * | Minor | 2.5      | 0.15 < D ≤ 0.25 | 2 | *     | 0.25 < D       | 0       | 1        |         |   |         |          |   |   |   |         |   |   |
| Zone<br>Dimension | Acceptable number                          |  |                   | Class of Defects  | AQL Level         |                  |                  |           |        |          |   |   |       |          |                 |   |       |                |         |          |         |   |         |          |   |   |   |         |   |   |
|                   | A  | B  |                   |                   |                   |                  |                  |           |        |          |   |   |       |          |                 |   |       |                |         |          |         |   |         |          |   |   |   |         |   |   |
| D ≤ 0.15          | *  | *  | Minor             | 2.5               |                   |                  |                  |           |        |          |   |   |       |          |                 |   |       |                |         |          |         |   |         |          |   |   |   |         |   |   |
| 0.15 < D ≤ 0.25   | 2  | *  |                   |                   |                   |                  |                  |           |        |          |   |   |       |          |                 |   |       |                |         |          |         |   |         |          |   |   |   |         |   |   |
| 0.25 < D          | 0  | 1  |                   |                   |                   |                  |                  |           |        |          |   |   |       |          |                 |   |       |                |         |          |         |   |         |          |   |   |   |         |   |   |

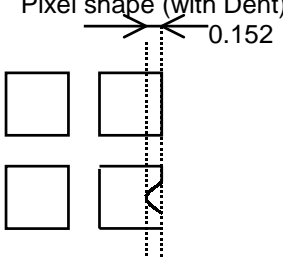
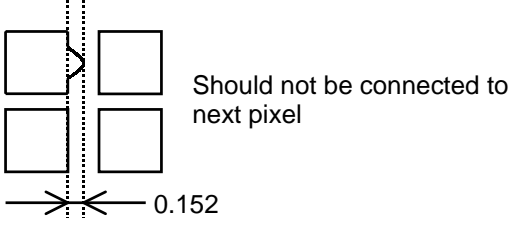
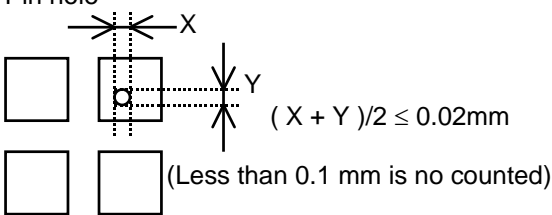
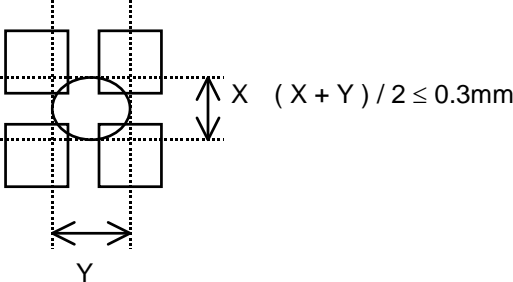
|          |                            |  |
|----------|----------------------------|--|
| <p>3</p> | <p>Uniformity of Pixel</p> | <p>(1) Pixel shape (with Dent)</p>  <p>(2) Pixel shape (with Projection)</p>  <p>(3) Pin hole</p>  <p>(4) Deformation</p>  <p>Total acceptable number : 1/pixel, 5/cell</p> |
|----------|----------------------------|--|

## 12. LOT NUMBERING SYSTEM

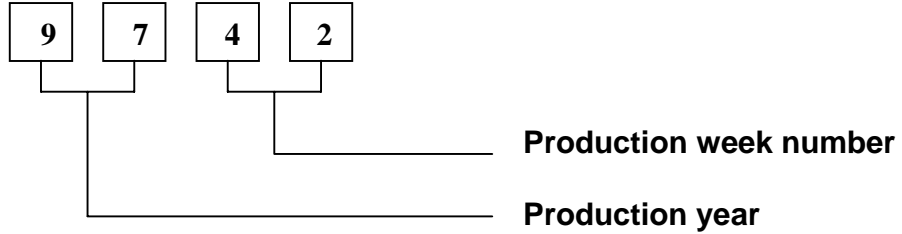

## 13. LCM NUMBERING SYSTEM

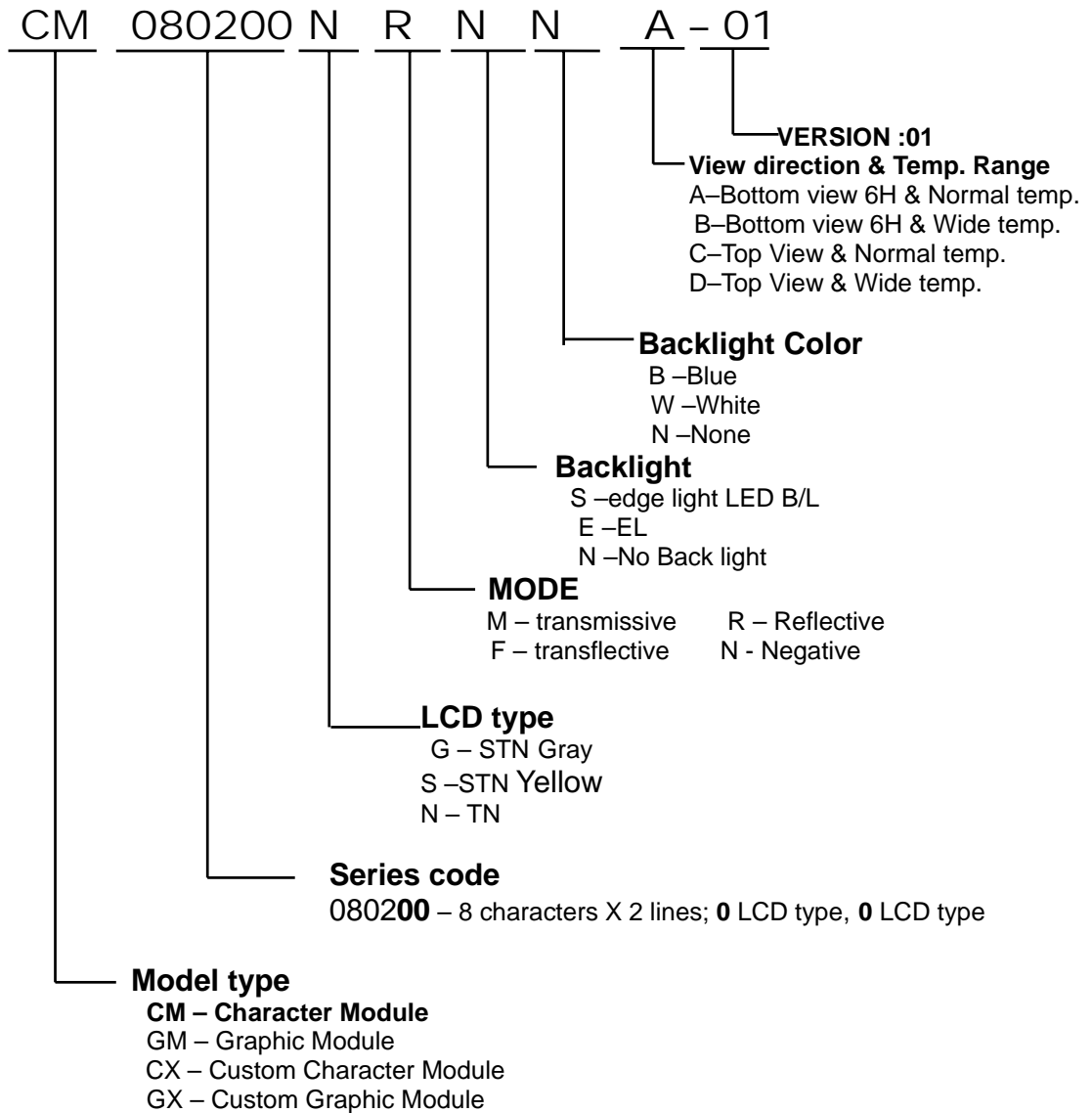

## 14. PRECAUTION FOR USING LCM

### 1. LIQUID CRYSTAL DISPLAY (LCD)

LCD is made up of glass, organic sealant, organic fluid, and polymer based polarizers. The following precautions should be taken when handling,

- (1). Keep the temperature within range of use and storage. Excessive temperature and humidity could cause polarization degradation, polarizer peel off or bubble.
- (2). Do not contact the exposed polarizers with anything harder than an HB pencil lead. To clean dust off the display surface, wipe gently with cotton, chamois or other soft material soaked in petroleum benzin.
- (3). Wipe off saliva or water drops immediately. Contact with water over a long period of time may cause polarizer deformation or color fading, while an active LCD with water condensation on its surface will cause corrosion of ITO electrodes.
- (4). Glass can be easily chipped or cracked from rough handling, especially at corners and edges.
- (5). Do not drive LCD with DC voltage.

### 2. Liquid Crystal Display Modules

#### 2.1 Mechanical Considerations

LCM are assembled and adjusted with a high degree of precision. Avoid excessive shocks and do not make any alterations or modifications. The following should be noted.

- (1). Do not tamper in any way with the tabs on the metal frame.
- (2). Do not modify the PCB by drilling extra holes, changing its outline, moving its components or modifying its pattern.
- (3). Do not touch the elastomer connector, especially insert an backlight panel (for example, EL).
- (4). When mounting a LCM make sure that the PCB is not under any stress such as bending or twisting. Elastomer contacts are very delicate and missing pixels could result from slight dislocation of any of the elements.
- (5). Avoid pressing on the metal bezel, otherwise the elastomer connector could be deformed and lose contact, resulting in missing pixels.

#### 2.2. Static Electricity

LCM contains CMOS LSI's and the same precaution for such devices should apply, namely

- (1). The operator should be grounded whenever he/she comes into contact with the module. Never touch any of the conductive parts such as the LSI pads, the copper leads on the PCB and the interface terminals with any parts of the human body.
- (2). The modules should be kept in antistatic bags or other containers resistant to static for storage.
- (3). Only properly grounded soldering irons should be used.
- (4). If an electric screwdriver is used, it should be well grounded and shielded from commutator sparks.

- (5) The normal static prevention measures should be observed for work clothes and working benches; for the latter conductive (rubber) mat is recommended.
- (6). Since dry air is inductive to statics, a relative humidity of 50-60% is recommended.

#### 2.3 Soldering

- (1). Solder only to the I/O terminals.
- (2). Use only soldering irons with proper grounding and no leakage.
- (3). Soldering temperature :  $280^{\circ}\text{C} \pm 10^{\circ}\text{C}$
- (4). Soldering time: 3 to 4 sec.
- (5). Use eutectic solder with resin flux fill.
- (6). If flux is used, the LCD surface should be covered to avoid flux spatters. Flux residue should be removed after wards.

#### 2.4 Operation

- (1). The viewing angle can be adjusted by varying the LCD driving voltage  $V_0$ .
- (2). Driving voltage should be kept within specified range; excess voltage shortens display life.
- (3). Response time increases with decrease in temperature.
- (4). Display may turn black or dark blue at temperatures above its operational range; this is (however not pressing on the viewing area) may cause the segments to appear "fractured".
- (5). Mechanical disturbance during operation (such as pressing on the viewing area) may cause the segments to appear "fractured".

#### 2.5 Storage

If any fluid leaks out of a damaged glass cell, wash off any human part that comes into contact with soap and water. Never swallow the fluid. The toxicity is extremely low but caution should be exercised at all the time.

#### 2.6 Limited Warranty

Unless otherwise agreed between DATA IMAGE and customer, DATA IMAGE will replace or repair any of its LCD and LCM which is found to be defective electrically and visually when inspected in accordance with DATA IMAGE acceptance standards, for a period on one year from date of shipment. Confirmation of such date shall be based on freight documents. The warranty liability of DATA IMAGE is limited to repair and/or replacement on the terms set forth above. DATA IMAGE will not responsible for any subsequent or consequential events.

# 15. OUTLINE DRAWING

UNITS MM

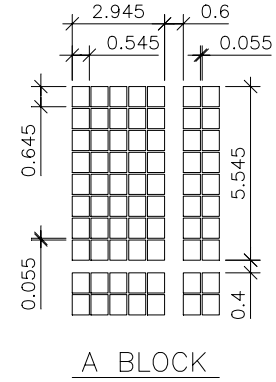
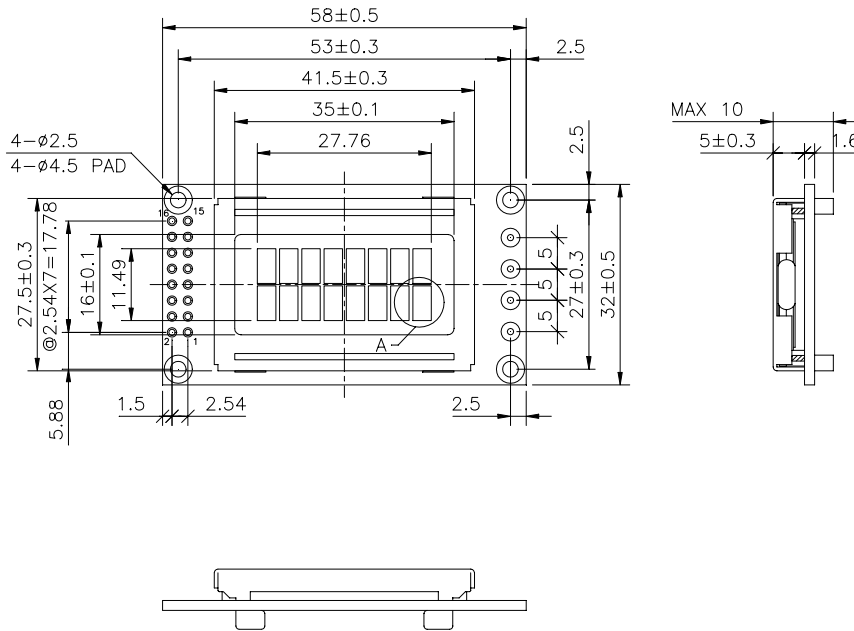

### PIN FUNCTIONS

|        |          |
|--------|----------|
| 1. VSS | 9. DB2   |
| 2. VDD | 10. DB3  |
| 3. VEE | 11. DB4  |
| 4. RS  | 12. DB5  |
| 5. R/W | 13. DB6  |
| 6. E   | 14. DB7  |
| 7. DB0 | 15. LEDA |
| 8. DB1 | 16. LEDK |

## 16. PACKAGE INFORMATION

